

1. Features

- Small footprint Buck converter for up to 3A output current application
- Low EMI noise using an inductor-embedded ferrite substrate
- High efficiency using synchronous rectifier technology at 2MHz operation
- Wide input voltage range : 2.7 to 5.5V
- User Adjustable Output voltage : 0.8 to 3.6V
- Superior transient response using quasi-fixed-frequency COT technology
- Seamless Power-Save Mode Transition
- Powergood function
- Over current protection, Over temperature protection



2. Description

The LXDC55K series is a high-power density synchronous step down converter optimized for small solution size, high efficiency and suitable for battery powered applications. To maximize efficiency, the converter operates in PWM mode at heavy load and automatically enters Power Save Mode operation at light load currents. Power Save Mode is entered automatically and seamlessly maintaining high efficiency over the entire load current range. The LXDC55K series utilizes a constant on time feedback technology and has excellent load transient response. It has a unique circuit that roughly keeps the switching frequency constant, which makes it easy to filter the switching noise. The device utilizes an inductor-embedded ferrite substrate, and the substrate eliminates radiated EMI noise and conduction noise efficiently.

The output voltage of LXDC55K series can be adjusted from 0.8 V to 3.6 V by using a resistor (RFB) between FB pin and GND pin. In terms of resistor value is calculated by $RFB = 5.44 / (V_{out} - 0.8V) - 1.6$ [kohm] .

The LXDC55K series has Power Good Output function. It's to indicate whether the output voltage has reached its appropriate level or not.

3. Typical Application Circuit

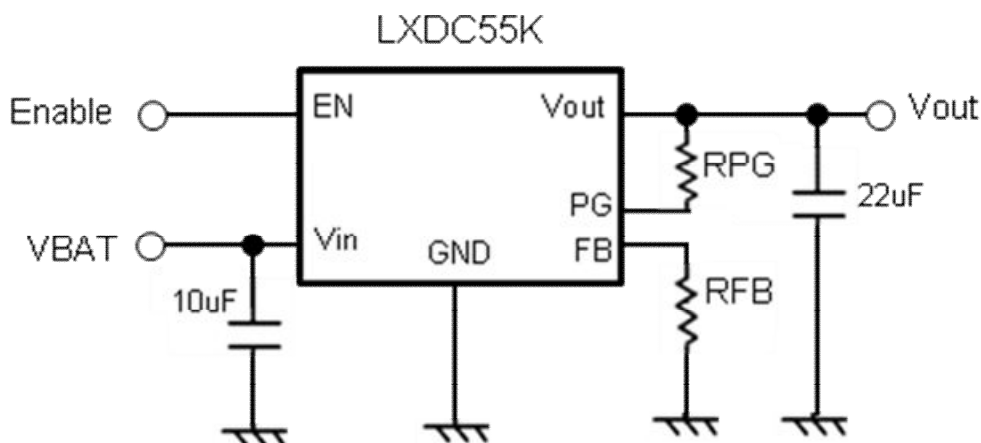

4. Mechanical Details

4-1 Outline

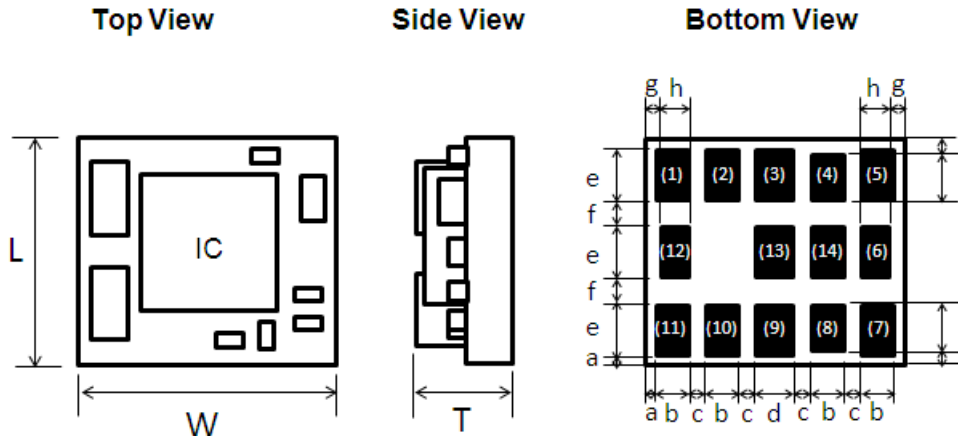

Unit:mm

Mark	Dimension	Mark	Dimension
L	5.0 +/- 0.2	e	1.1
W	5.7 +/- 0.2	f	0.6
T	2.1 MAX	g	0.35
a	0.25	h	0.6
b	0.7	i	0.35
c	0.4	j	1.0
d	0.8		

4-2. Pin Function

Pin No.	Symbol	I/O	Description
1	EN	Input	This is the ON/OFF control pin of the device. The device is in shutdown when the voltage to this pin is below 0.4V. Pulling this pin above 1.0V enables the device with soft start. This pin should not be left floating. This pin is pulled down to GND with 400kohm resistor. EN=H: Device ON, EN=L: Device OFF
4,5	Vin	Input	Vin pin supplies current to the LXDC55K internal regulator.
6,12	GND	-	Ground pin
7,8	Vout	Output	Regulated voltage output pin. Apply output load between this pin and GND
10	PG	Output	Power good voltage output pin (Open drain). This is to indicate whether the output voltage has reached its appropriate level or not.
11	FB	Input	External resistor connection pin for output voltage setting
2,3,9,13,14	NC	-	No connection This pin can be connected to any other pins

4-3. Functional Block Diagram

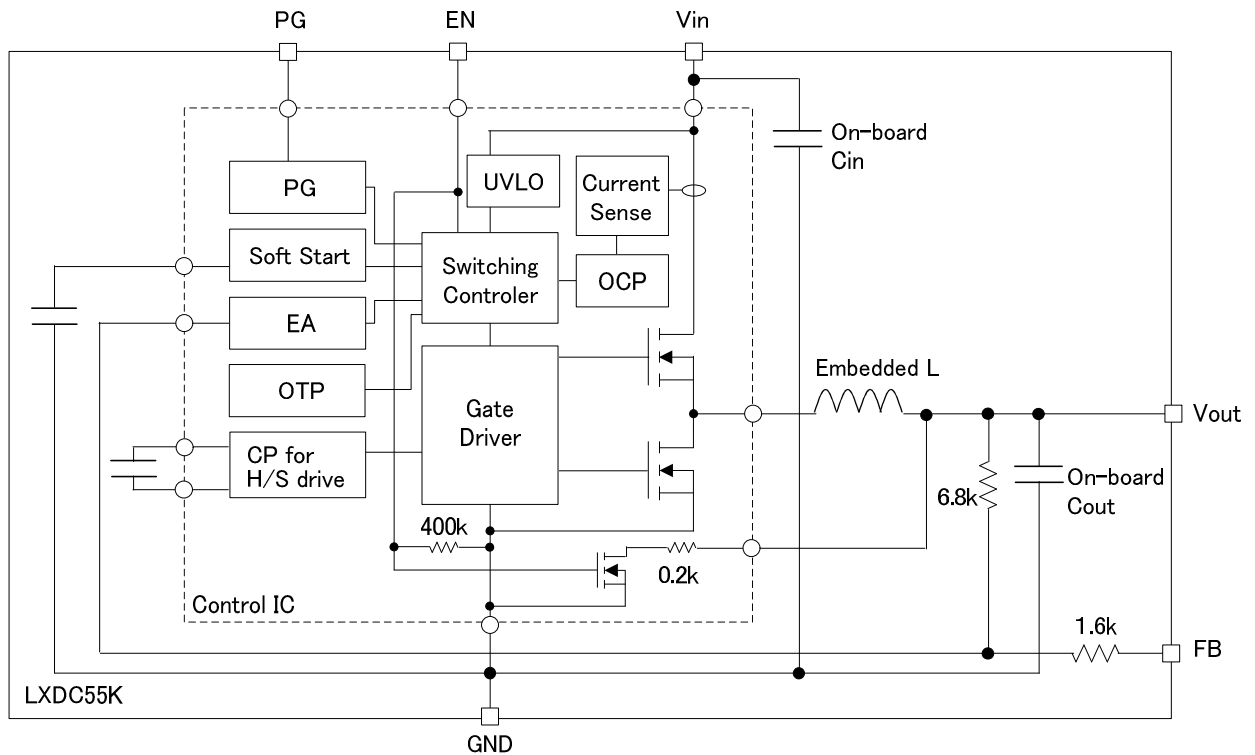

5. Ordering Information

Part number	Device Specific Feature	MOQ
LXDC55KAAA-205	Standard Type	T/R, 1,000pcs/R
LXDC55KAAAA205	Standard Type	T/R, 300pcs/R

6. Electrical Specification

6-1 Absolute maximum ratings

Parameter	symbol	rating	Unit
Input voltage	Vin, EN, FB	6	V
Operating Ambient temperature	Ta	-40 to +85	°C
Operating IC temperature	T _{IC}	-40 to +125	°C
Storage temperature	T _{STO}	-40 to +85	°C

6-2 Electrical characteristics (Ta=25°C)

Parameter	Symbol	Condition	Min.	Typ.	Max.	Unit
Input voltage	Vin		2.7		5.5	V
Output voltage range	Vout		0.8		3.6	V
UVLO	UVLO	Vin Falling	2.1	2.2	2.3	V
		hysteresis		200		mV
Standby current	IinOFF	Vin=5V, EN=0.4V		2	6	uA
Quiescent current	Iin0	Vin=5V, RFB=576Ω (Vout=3.3V) Iout=0A		320	420	uA
Output voltage accuracy	Vacc	PWM mode	-2.5		+2.5	%
Load current range	Iout		0		3000	mA
Over current protection	OCP	Auto-recovery	3000		5500	mA
Ripple voltage	Vrpl	Vin=5V, RFB=576ohm, (Vout=3.3V) Iout=1500mA, BW=100MHz		20		mV
Efficiency	EFF	Vin=5V, RFB=576ohm, (Vout=3.3V) Iout=1500mA		93		%
EN control voltage	VENH	ON ; Enable	1.0		Vin	V
	VENL	OFF ; Disable	0		0.4	V
Switching frequency	fosc	Vin=5V, RFB=576Ω (Vout=3.3V) Iout=1500mA		2.0		MHz
Power good threshold	PGTHH	Output voltage rising		95		%
	PGTHL	Output voltage falling		90		%
Power good sink current	IPG				1	mA

(*1) External capacitors (Cin:10uF,Cout:22uF) shall be placed near the module in order to proper operation.

(*2) The above characteristics are tested using the application circuit on section 8.

6-3 Thermal and Current De-rating Information

The following figure shows the power dissipation and temperature rise characteristics example. These data are measured on Murata's evaluation board of this device at no air-flow condition.

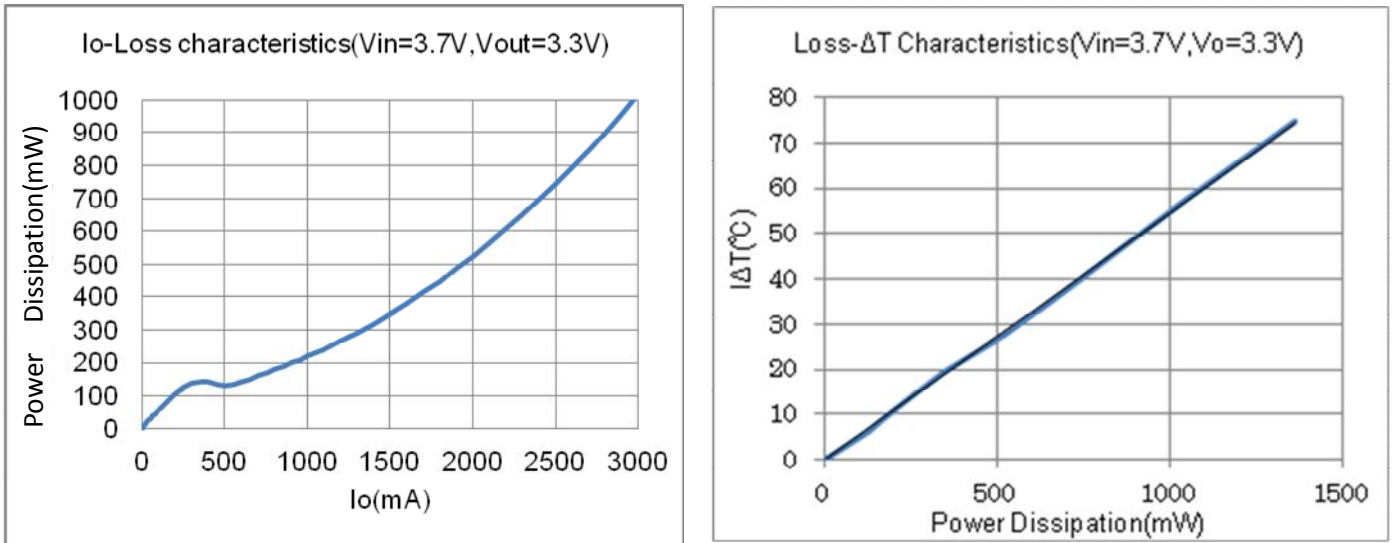

The output current of the device may need to be de-rated if it is operated in a high ambient temperature or in a continuous power delivering application. The amount of current de-rating is highly dependent on the environmental thermal conditions, i.e. PCB design, nearby components or effective air flows. Care should especially be taken in applications where the device temperature exceeds 85°C.

The IC temperature of the device must be kept lower than the maximum rating of 125 °C. It is generally recommended to take an appropriate de-rating to IC temperature for a reliable operation. A general de-rating for the temperature of semiconductor is 80%.

MLCC capacitor's reliability and lifetime are also depending on temperature and applied voltage stress. Higher temperature and/or higher voltage cause shorter lifetime of MLCC, and the degradation can be described by the Arrhenius model. The most critical parameter of the degradation is IR (Insulation Resistance). The below figure shows MLCC's B1 life based on a failure rate reaching 1%. It should be noted that wear-out mechanisms in MLCC capacitor is not reversible but cumulative over time.

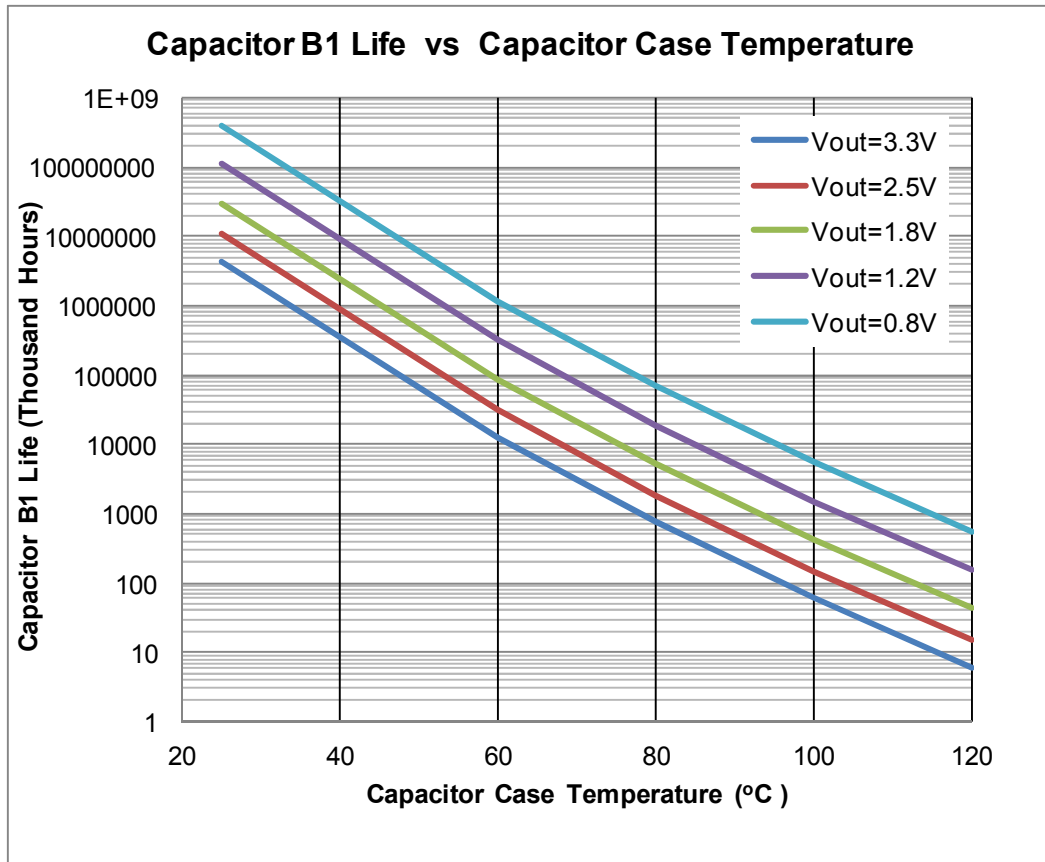

The following steps should be taken before the design fix of user's set for a reliable operation.

1. The ambient temperature of the device should be kept below 85 °C
2. The IC temperature should be measured on the worst condition of each application. The temperature must be kept below 125 °C. An appropriate de-rating of temperature and/or output current should be taken.
3. The MLCC temperature should be measured on the worst condition of each application. Considering the above figure, it should be checked if the expected B1 life of MLCC is acceptable or not.

7. Detailed Description

Adjustable output voltage

The output voltage of LXDC55K series can be adjusted from 0.8 V to 3.6 V by using a resistor (RFB) between FB pin and GND pin. In terms of resistor value is calculated by $RFB = 5.44/(V_{out}-0.8V) - 1.6$ [kohm]

PWM Operation

At medium to heavy load currents, the device operates with pulse width modulation (PWM). As the load current decreases, the converter enters the Power Save Mode operation reducing its switching frequency. The device enters Power Save Mode at the boundary to discontinuous conduction mode (DCM).

Power Save Mode Operation

As the load current decreases, the converter enters Power Save Mode operation. During Power Save Mode the converter operates with reduced switching frequency in PFM mode and with a minimum quiescent current while maintaining high efficiency.

UVLO (Under Voltage Lock Out)

The input voltage (V_{in}) must reach or exceed the UVLO voltage (2.2V_{typ}) before the device begins the start up sequence even when EN pin kept high. UVLO function keeps away of an unstable operation at low V_{in} range

Soft Start

The device has an internal soft-start function that limits the inrush current during start-up. The soft-start system progressively increases the switching on-time from a minimum pulse-width to that of normal operation. Because of the function, the output voltage increases gradually from zero to nominal voltage at start-up event. The typical soft-start time is set to 800usec.

Enable

The device starts operation when EN is set high and starts up with soft start. For proper operation, the EN pin must be terminated to logic high and must not left floating. Pulling the EN pin to logic low forces the device shutdown. This pin is pulled down internally to GND by 400kohm resistor.

Power Good (PG)

The device has a built-in power-good (PG) function to indicate whether the output voltage has reached its appropriate level or not. It can sink 1 mA of current and maintain its specified logic-low level.

Over Current Protection

The device integrates a current limit function to protect internal components against heavy load or short circuit. If the OCP event is removed, the output voltage recovers to the nominal value automatically.

Thermal Shutdown

As soon as the internal IC's junction temperature exceeds 150°C (typ), the device goes into thermal shutdown. The device continues its operation when the Internal IC's junction temperature again falls below 130°C (typ).

Discharge Function

To make sure the device starts up under defined conditions, the output gets discharged with a typical discharge resistor of 200 Ω whenever the device shuts down. This happens when the device is disabled or if thermal shutdown, under voltage lockout or over current protection is triggered.

100% Duty Cycle Operation

The device offers low input to output voltage difference by entering 100% duty cycle mode. In this mode the high side MOSFET switch is constantly turned on. This is particularly useful in battery powered applications to achieve longest operation time by taking full advantage of the whole battery voltage range.

8. Test Circuit

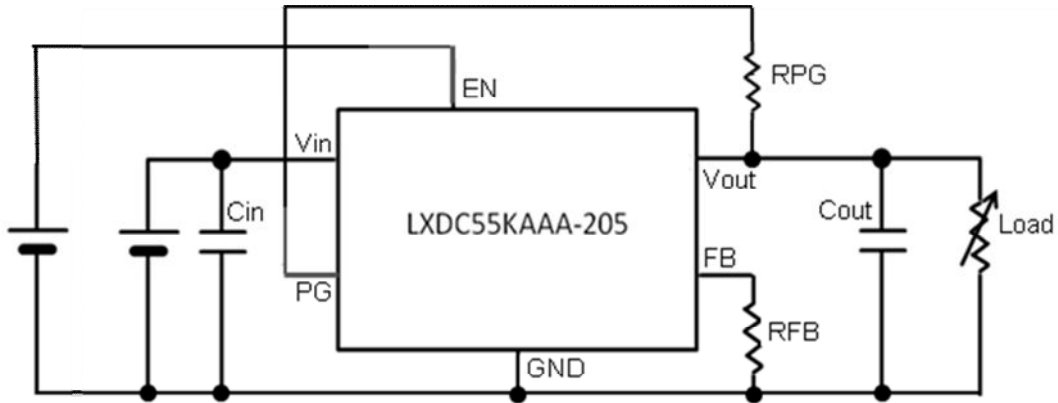

Cin : GRM21BB30J106 (10uF/6.3V MLCC)

Cout : GRM21BB30J226 (22uF/6.3V MLCC)

9. Output Voltage adjustment

Output voltage can be adjusted by using a resistor (RFB) between FB pin and GND pin.

$$RFB = 5.44 / (Vout - 0.8V) - 1.6 \text{ [kohm]}$$

RFB Example

Vout(V)	RFB(kohm)	Vout(V)	RFB(kohm)
0.8	OPEN	2.5	1.600
1.2	12.00	3.0	0.8727
1.5	6.171	3.3	0.5760
1.8	3.840	3.6	0.3429

10. Measurement Data

Micro DC-DC Converter evaluation board (P2LX1568F)

Measurement setup

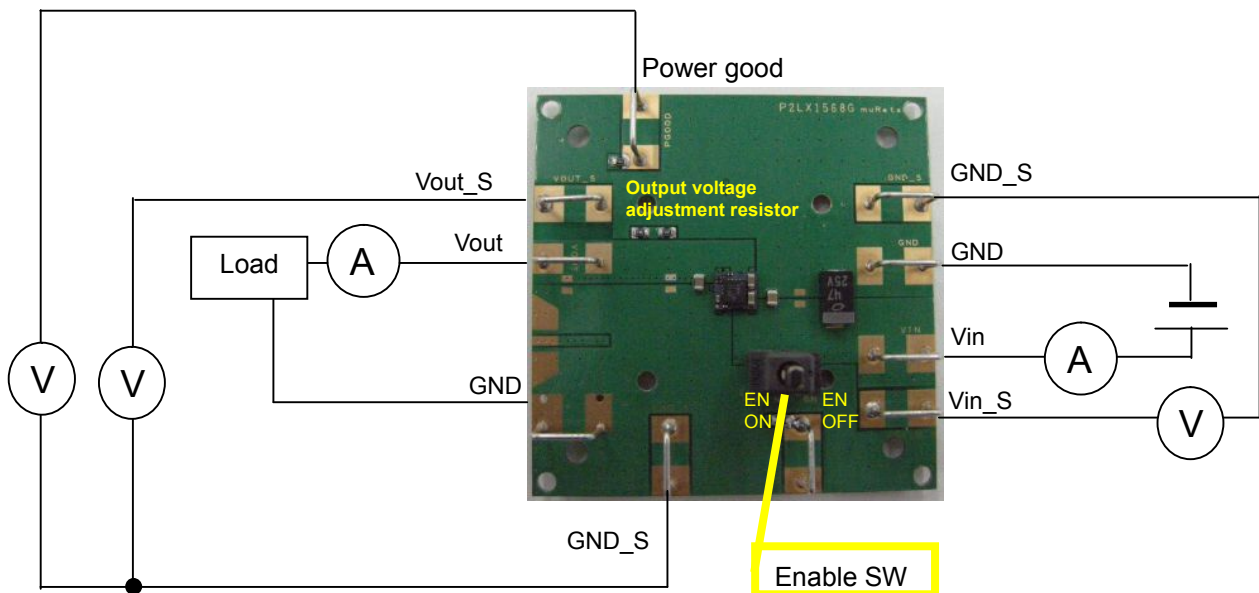

*** Evaluation board initial output Voltage setting : 3.3V (resistor : 560Ω + 16Ω)**

The enable switch has three positions.

1. When it is toggled to “ON” side, the device starts operation.
2. When it is toggled to “OFF” side, the device stop operation and keep shut down status.
3. When it is set to middle of “ON” and “OFF”, the EN pin becomes floated and can be applied an external voltage through the EN terminal pin on the EVB. If you don't apply external voltage to EN pin, the enable switch should not to be set to the middle position.

※The 47uF capacitor is for the evaluation kit only, and has been added to compensate for the long test cables.

Typical Measurement Data (reference purpose only) (Ta=25°C)

Efficiency

Vin=5.0V,

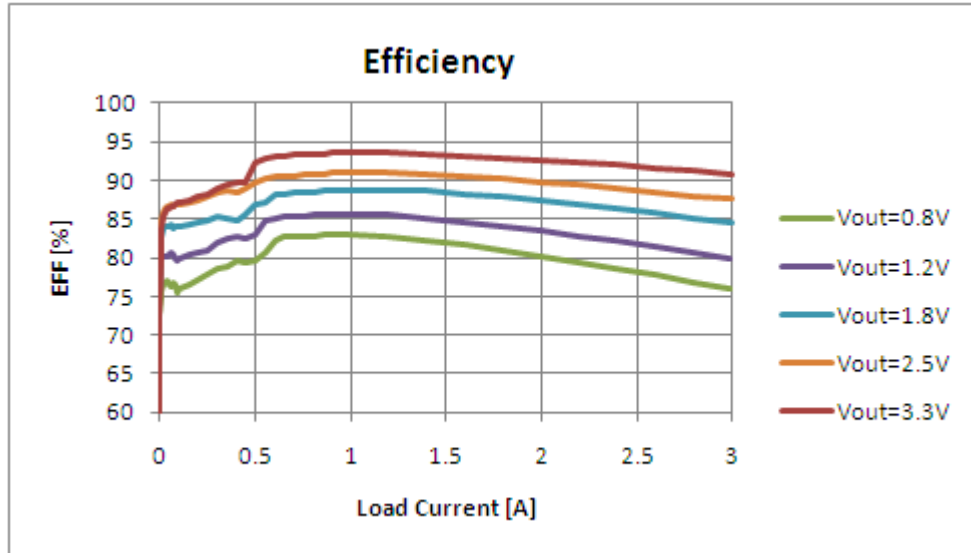

Output Ripple-Noise

Vin=5.0V, BW : 100MHz

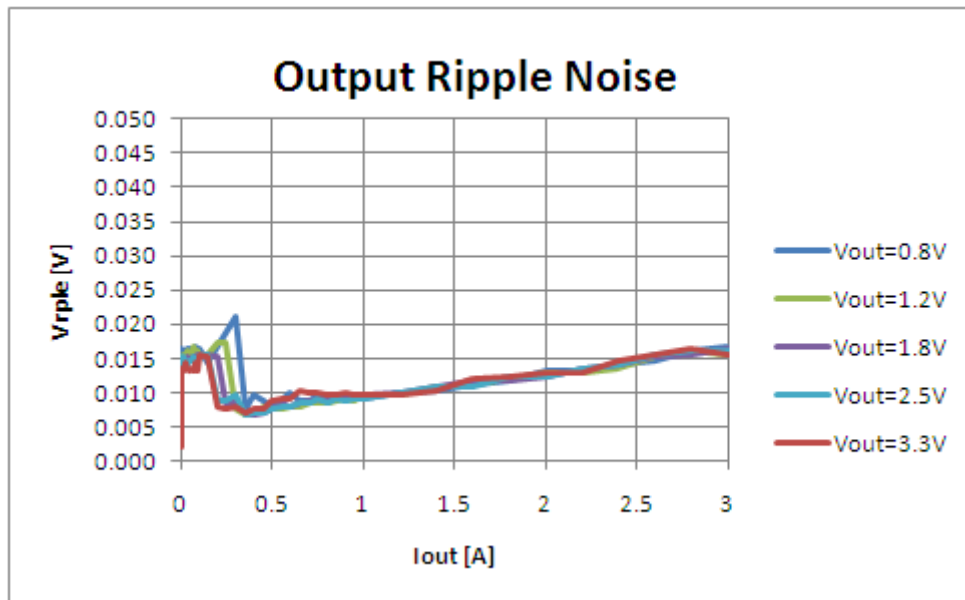

Load Regulation

Vin=5.0V, Vout=0.8V

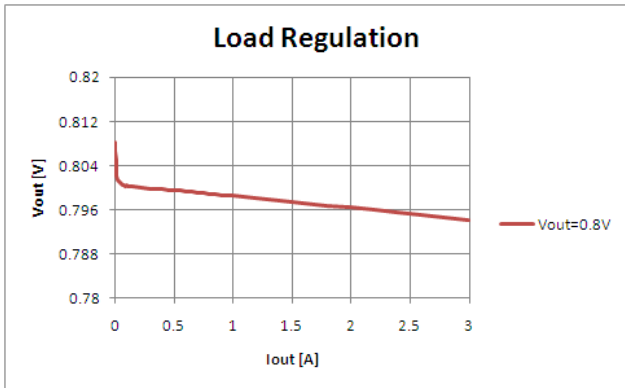

Vin=5.0V, Vout=1.2V

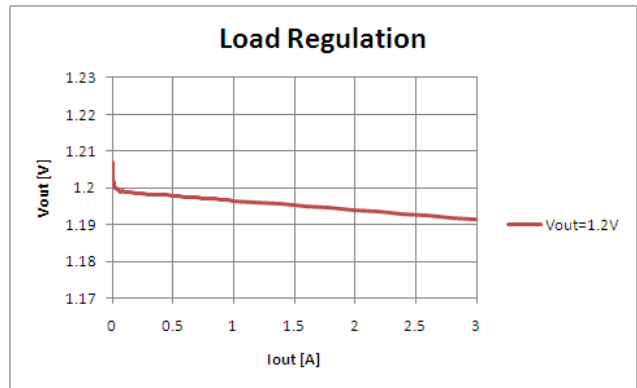

Vin=5.0V, Vout=1.8V

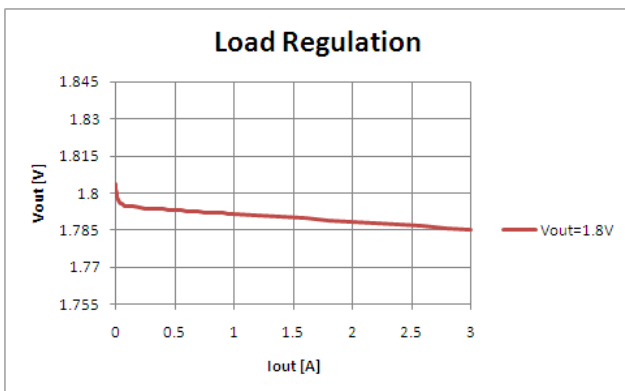

Vin=5.0V, Vout=2.5V

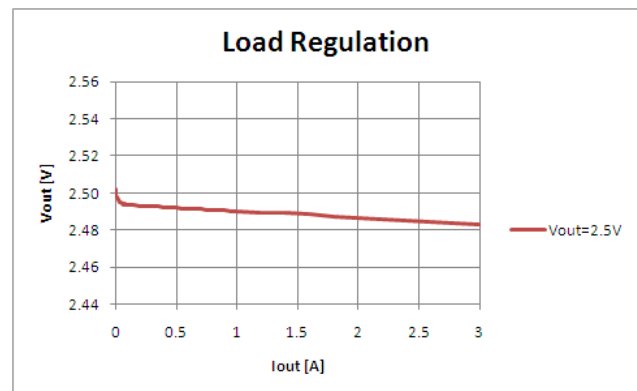

Vin=5.0V, Vout=3.3V

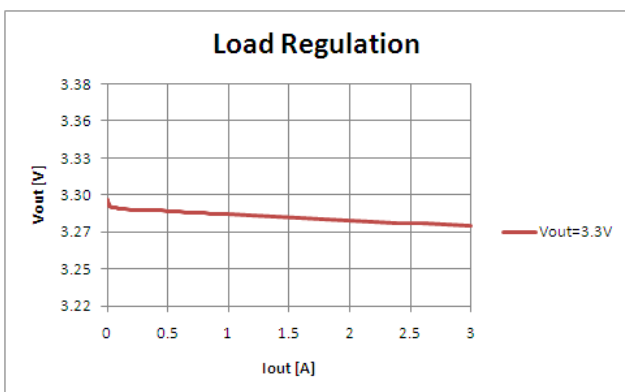

Typical Measurement Data (reference purpose only) (Ta=25°C)

Load Transient Response

• Vin=5.0V, Vout=3.3V

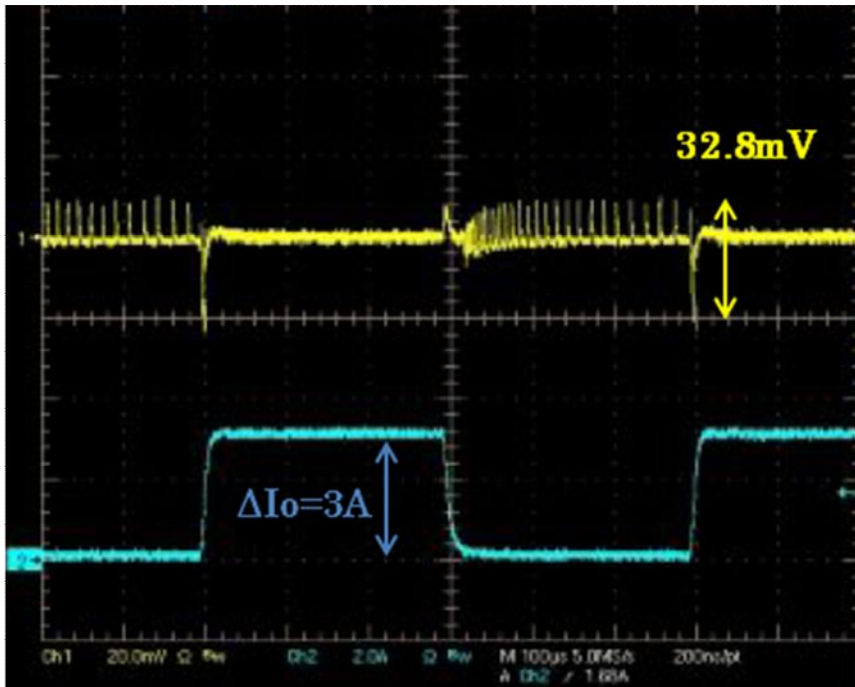

• Vin=5.0V, Vout=2.5V

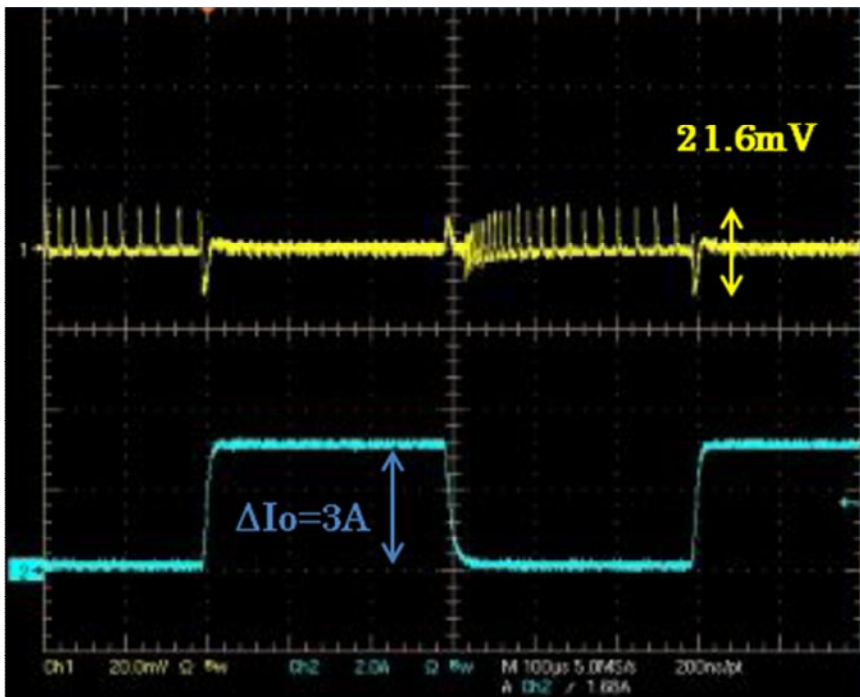

• $V_{in}=5.0V$, $V_{out}=1.8V$

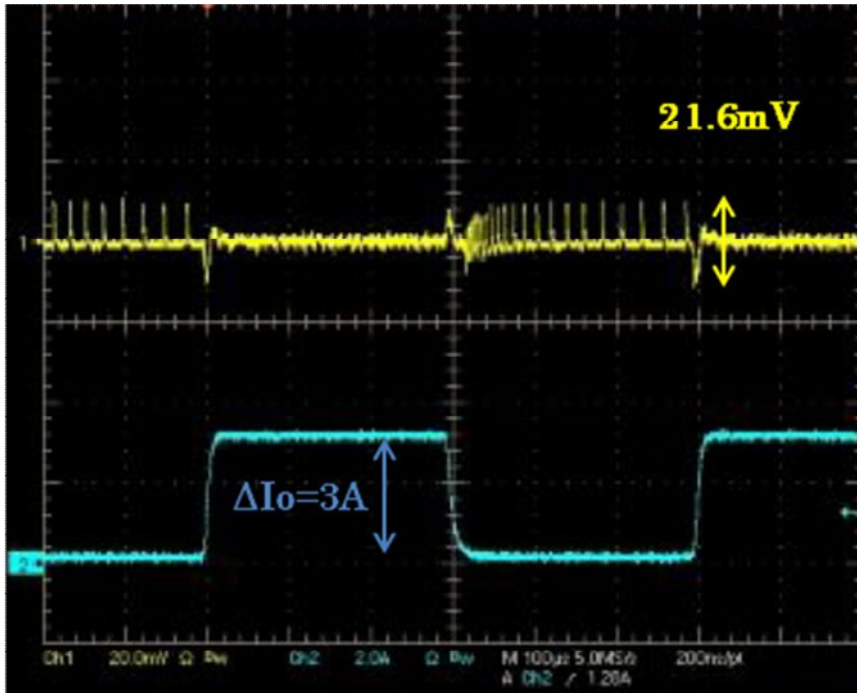

• $V_{in}=5.0V$, $V_{out}=1.2V$

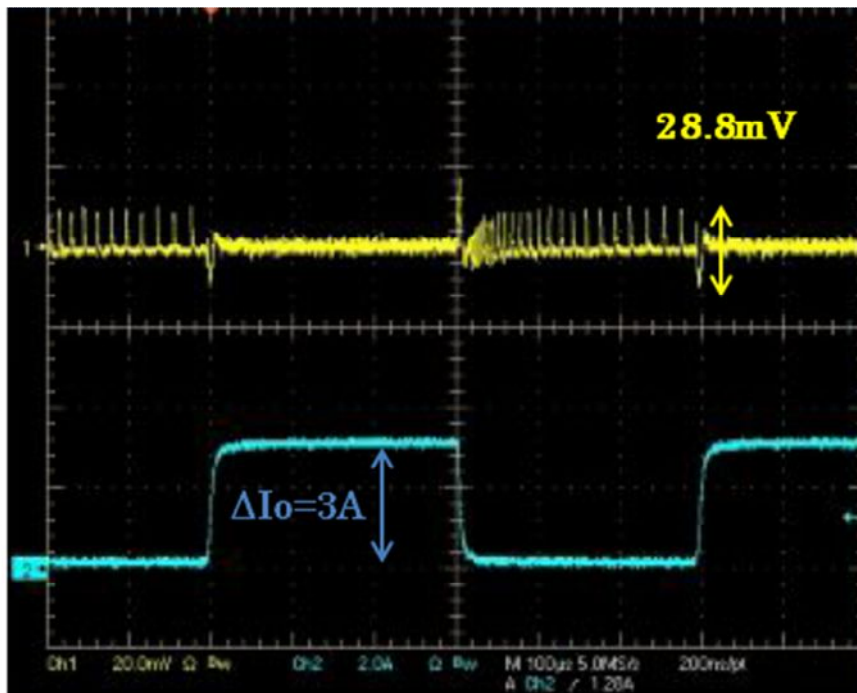

11. Reliability Tests

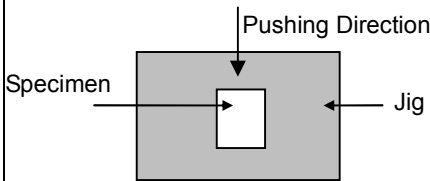
No.	Items	Specifications	Test Methods	QTY	Result (NG)	
1	Vibration Resistance	Appearance : No severe damages	Solder specimens on the testing jig (glass fluorine boards) shown in appended Fig.1 by a Pb free solder. The soldering shall be done either by iron or reflow and be conducted with care so that the soldering is uniform and free of defect such as by heat shock. Frequency : 10~2000 Hz Acceleration : 196 m/s ² Direction : X,Y,Z 3 axis Period : 2 h on each direction Total 6 h.	18	G (0)	
2	Deflection		Solder specimens on the testing jig (glass epoxy boards) shown in appended Fig.2 by a Pb free solder. The soldering shall be done either by iron or reflow and be conducted with care so that the soldering is uniform and free of defect such as by heat shock. Deflection : 1.6mm	18	G (0)	
3	Soldering strength (Push Strength)	9.8 N Minimum	Solder specimens onto test jig shown below. Apply pushing force at 0.5mm/s until electrode pads are peeled off or ceramics are broken. Pushing force is applied to longitudinal direction. 	18	G (0)	
4	Solderability of Termination	75% of the terminations is to be soldered evenly and continuously.	Immerse specimens first an ethanol solution of rosin, then in a Pb free solder solution for 3±0.5 sec. at 245±5 °C. Preheat : 150 °C, 60 sec. Solder Paste : Sn-3.0Ag-0.5Cu Flux : Solution of ethanol and rosin (25 % rosin in weight proportion)	18	G (0)	
5	Resistance to Soldering Heat (Reflow)	Appearance Electrical specifications	No severe damages Satisfy specifications listed in paragraph 6-2.	Preheat Temperature : 150-180 °C Preheat Period : 90+/-30 sec. High Temperature : 220 °C High Temp. Period : 20sec. Peak Temperature : 260+5/-0 °C Specimens are soldered twice with the above condition, and then kept in room condition for 24 h before measurements.	18	G (0)

No.	Items	Specifications	Test Methods	QTY	Result (NG)							
6	High Temp. Exposure	Appearance Electrical specifications	Temperature: 85±2 °C Period: 1000+48/-0 h Room Condition: 2~24h	18	G (0)							
7	Temperature Cycle		Condition: 100 cycles in the following table	18	G (0)							
<table border="1"> <thead> <tr> <th>Step</th> <th>Temp(°C)</th> <th>Time(min)</th> </tr> </thead> <tbody> <tr> <td>1</td> <td>Min. Operating Temp.+0/-3</td> <td>30±3</td> </tr> <tr> <td>2</td> <td>Max. Operating Temp.+3/-0</td> <td>30±3</td> </tr> </tbody> </table>			Step			Temp(°C)	Time(min)	1	Min. Operating Temp.+0/-3	30±3	2	Max. Operating Temp.+3/-0
Step	Temp(°C)		Time(min)									
1	Min. Operating Temp.+0/-3		30±3									
2	Max. Operating Temp.+3/-0		30±3									
8	Humidity (Steady State)	No severe damages Satisfy specifications listed in paragraph 6-2.	Temperature: 85±2 °C Humidity: 80~90%RH Period: 1000+48/-0 h Room Condition: 2~24h	18	G (0)							
9	Low Temp. Exposure		Temperature: -40±2 °C Period: 1000+48/-0 h Room Condition: 2~24h	18	G (0)							
10	ESD(Machine Model)		C: 200pF, R: 0Ω TEST Voltage : +/-100V Number of electric discharges: 1	5	G (0)							
11	ESD(Human Body Model)		C: 100pF, R: 1500Ω TEST Voltage : +/-1000V Number of electric discharges: 1	5	G (0)							

Fig.1
Land Pattern

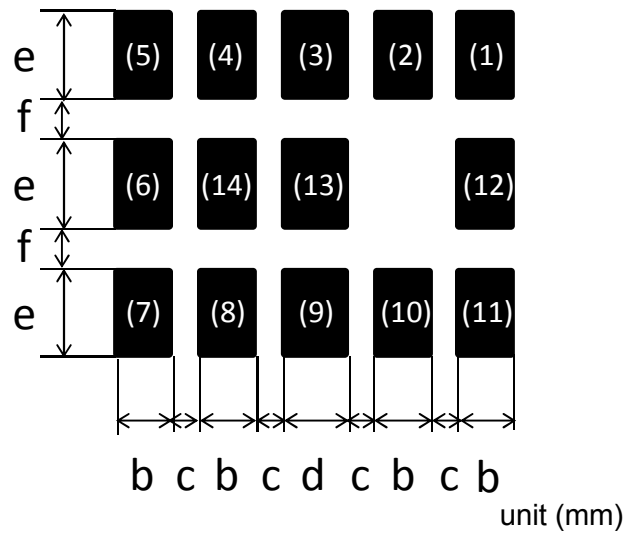

Mark	Dimension
b	0.7
c	0.4
d	0.8
e	1.1
f	0.6

•Reference purpose only.

Fig.2
Testing board

Unit: mm

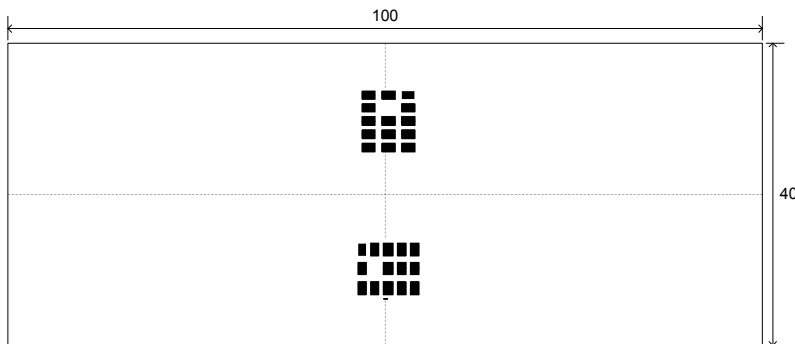

■ : Land pattern is same as figure 1
Glass-fluorine board $t=1.6\text{mm}$
Copper thickness over $35\ \mu\text{m}$

Mounted situation

Unit: mm

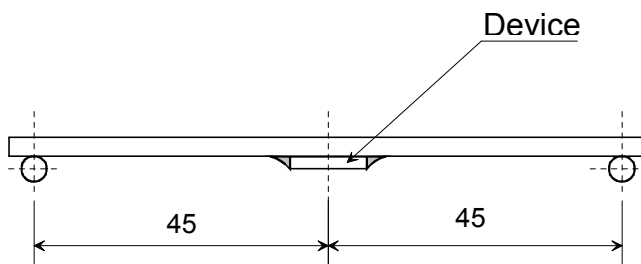

Test method

Unit: mm

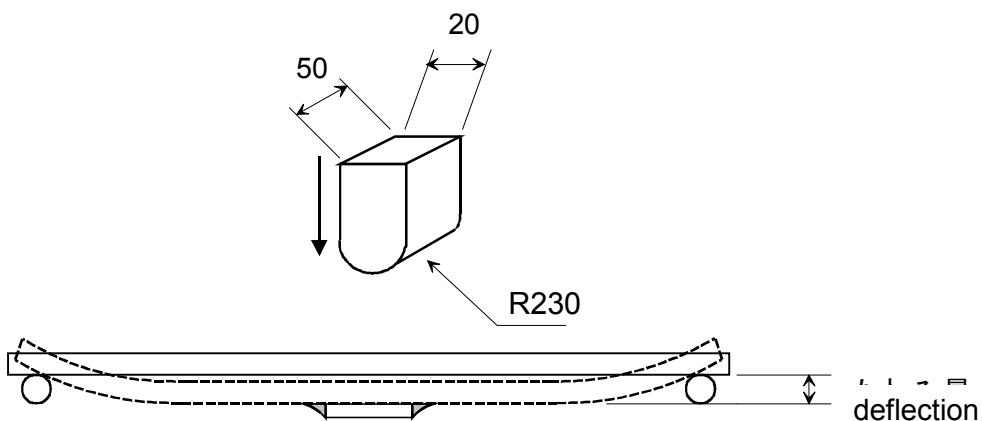

12. Tape and Reel Packing

1) Dimensions of Tape (Paper tape)

(Unit : mm)

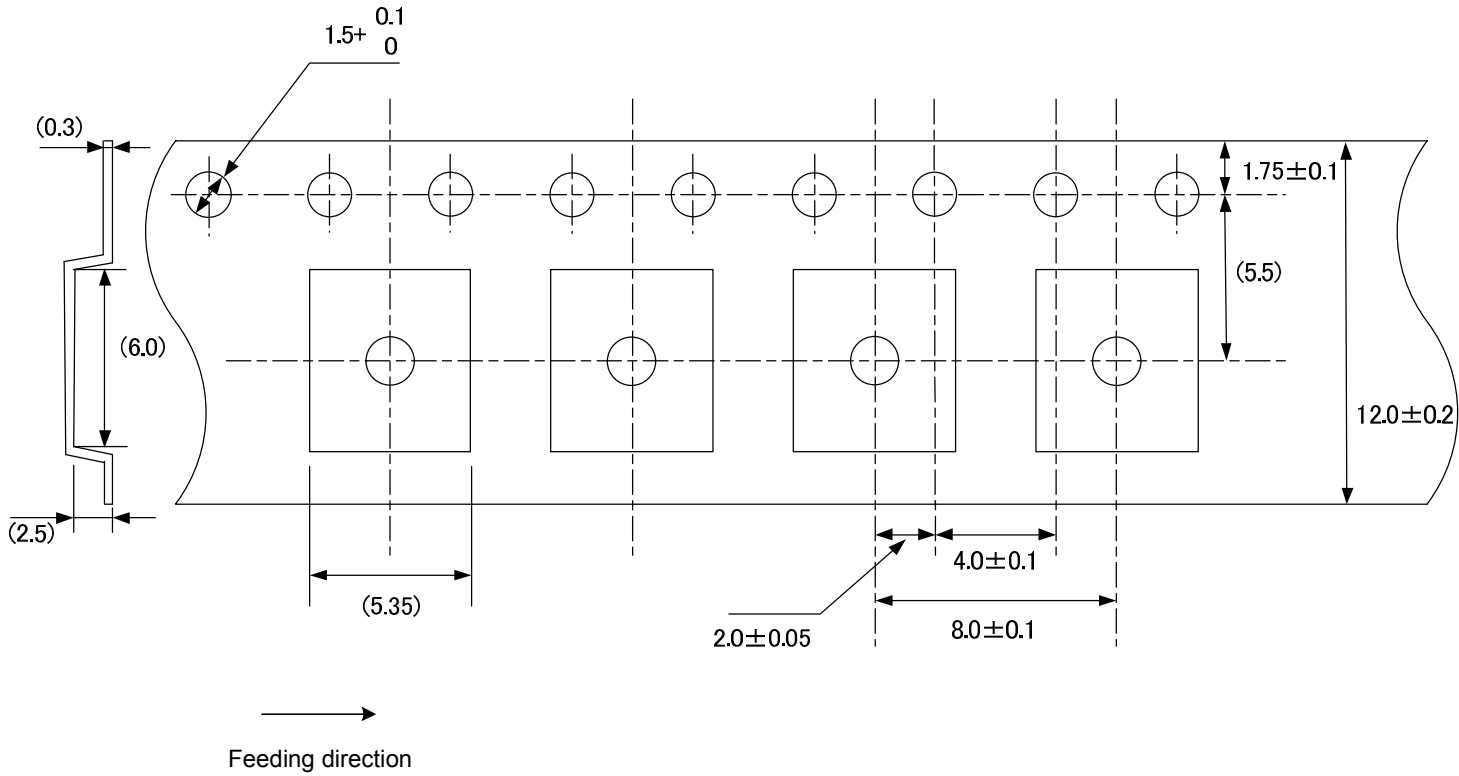

2) Dimensions of Reel

2-1. LXDC55KAAA-205 : 1,000pcs/reel

(Unit : mm)

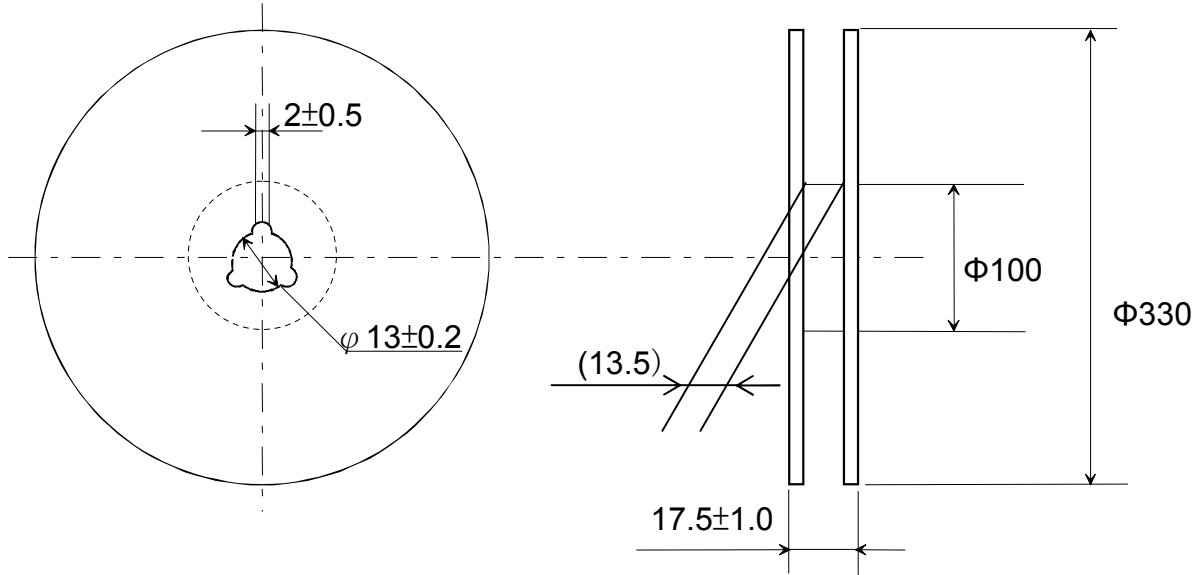

2-2. LXDC55KAAA205 : 300pcs/reel

Unit: mm

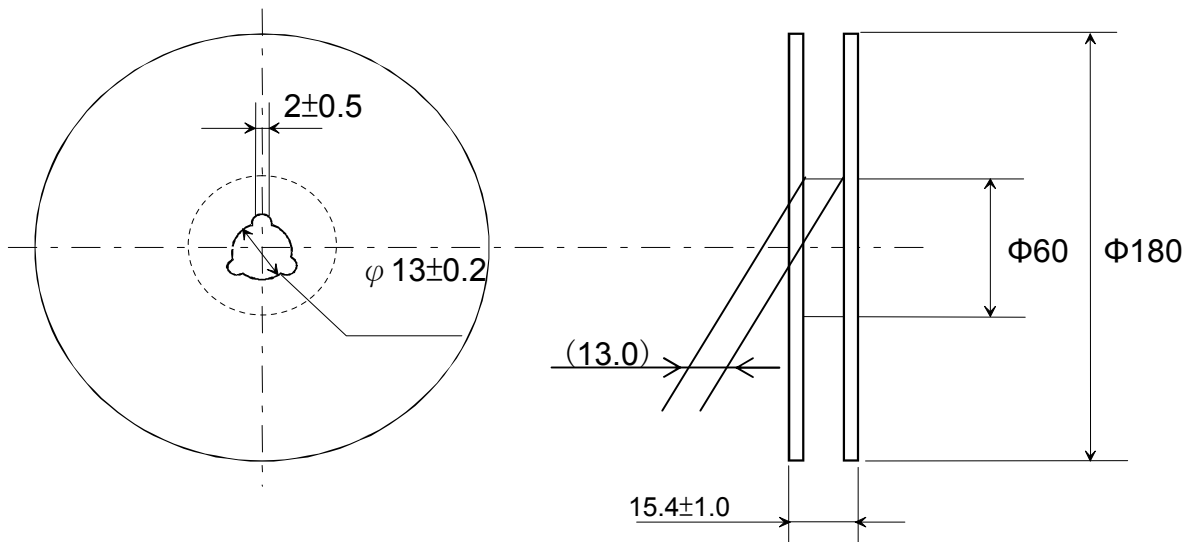

3) PACKAGE Diagrams (Humidity proof Packing)

Tape and reel must be sealed with the anti-humidity plastic bag. The bag contains the desiccant and the humidity indicator.

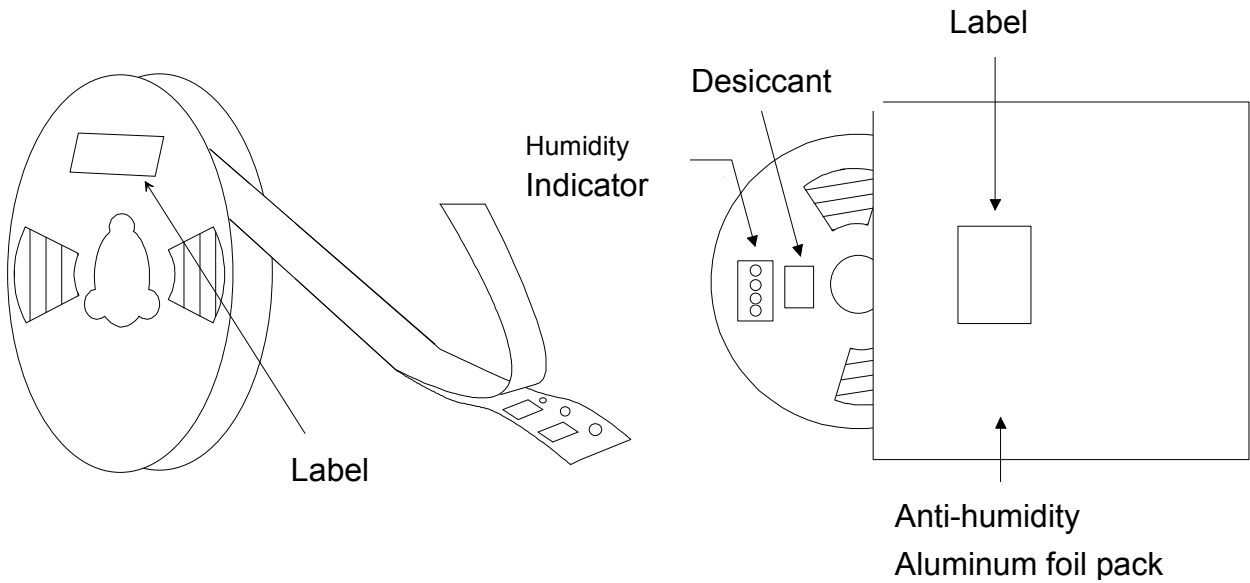

4) Taping Diagrams(LXDC55K)

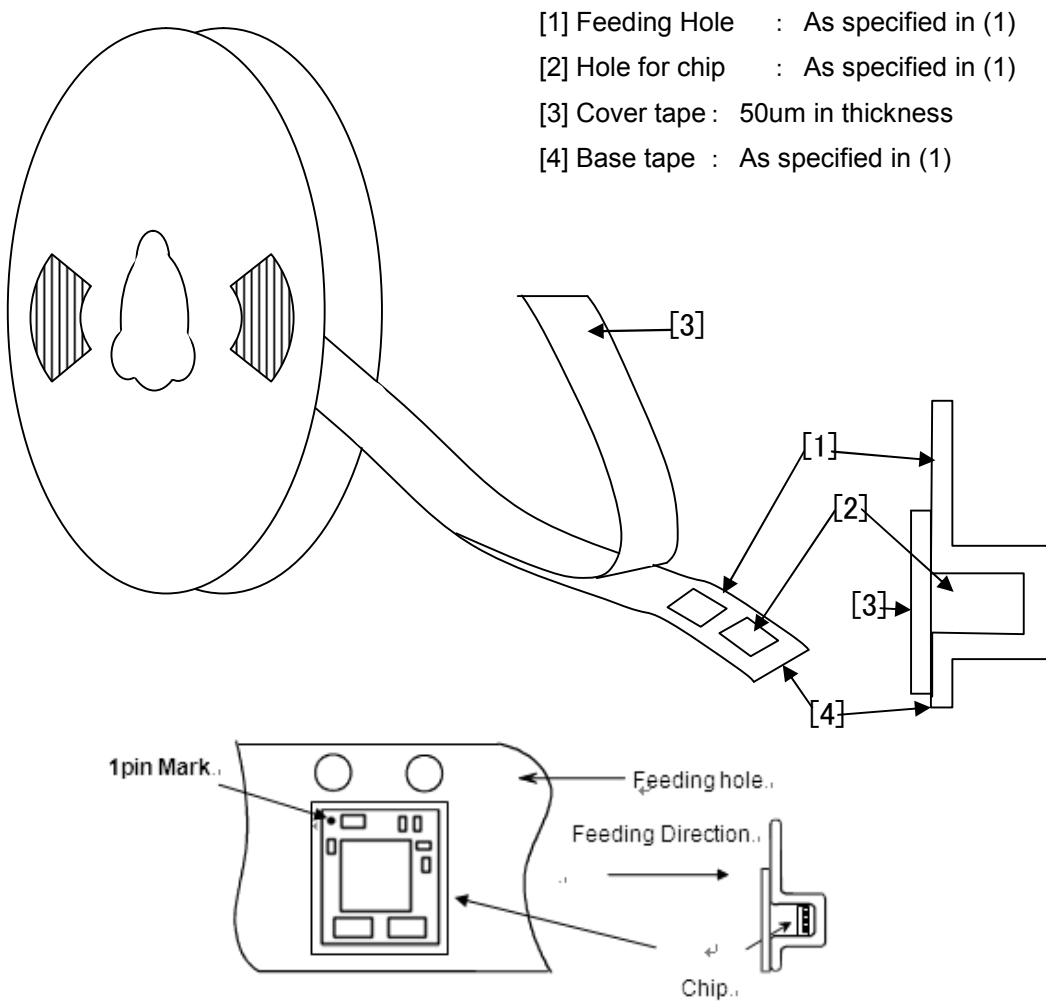

5) Leader and Tail tape

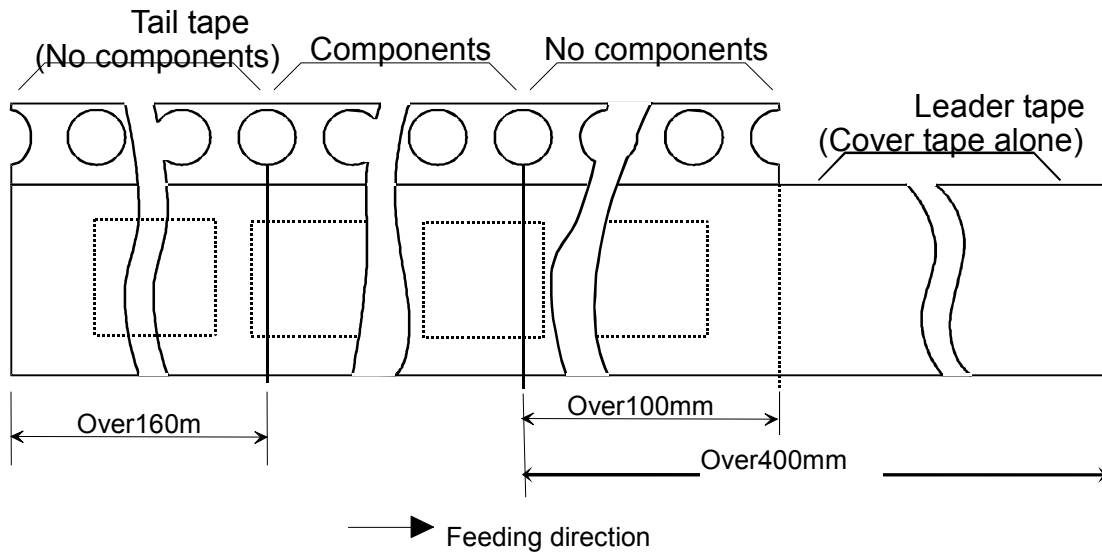

6) The tape for chips are wound clockwise, the feeding holes to the right side as the tape is pulled toward the user.

7) Material : Base tape Plastic
 Reel and Cover tape Plastic
 Base tape, Reel and Cover tape have an anti-ESD function.

8) Peeling of force : 0.1~1.3 N in the direction of peeling as shown below.

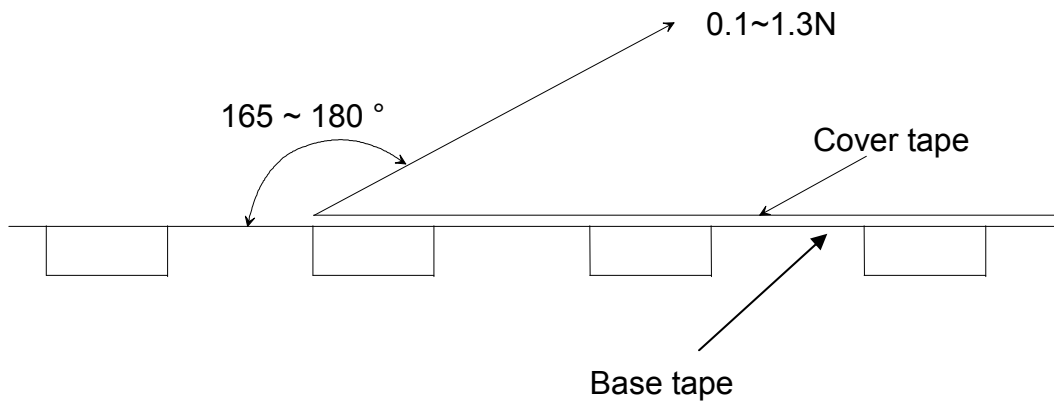

NOTICE

1. Storage Conditions:

- The product shall be stored without opening the packing under the ambient temperature from 5 to 35 deg.C and humidity from 20 to 70%RH.
(Packing materials, in particular, may be deformed at the temperature over 40 deg.C.)
- The product left more than 6 months after reception, it needs to be confirmed the solderability before used.
 - The product shall be stored in non corrosive gas (Cl₂, NH₃, SO₂, NO_x, etc.).
 - Any excess mechanical shock including, but not limited to, sticking the packing materials by sharp object and dropping the product, shall not be applied in order not to damage the packing materials.
- After the packing opened, the product shall be stored at ≤ 30 deg.C / ≤ 60 %RH and the product shall be used within 168 hours.

When the color of the indicator in the packing changed, the product shall be baked before soldering.

This product is applicable to MSL3 (Based on IPC/JEDEC J-STD-020)

2. Handling Conditions:

Be careful in handling or transporting the product. Excessive stress or mechanical shock may damage the product because of the nature of ceramics structure.
Do not touch the product, especially the terminals, with bare hands. Doing so may result in poor solderability.

3. Standard PCB Design (Land Pattern and Dimensions):

All the ground terminals should be connected to ground patterns. Furthermore, the ground pattern should be provided between IN and OUT terminals. Please refer to the specifications for the standard land dimensions.

The recommended land pattern and dimensions are shown for a reference purpose only.
Electrical, mechanical and thermal characteristics of the product shall depend on the pattern design and material / thickness of the PCB. Therefore, be sure to check the product performance in the actual set.
When using underfill materials, be sure to check the mechanical characteristics in the actual set.

4. Soldering Conditions:

Soldering is allowed up through 2 times.

Carefully perform preheating : ΔT less than 130 °C.

When products are immersed in solvent after mounting, pay special attention to maintain the temperature difference within 100 °C. Soldering must be carried out by the above mentioned conditions to prevent products from damage. Contact Murata before use if concerning other soldering conditions

Reflow soldering standard conditions (example)

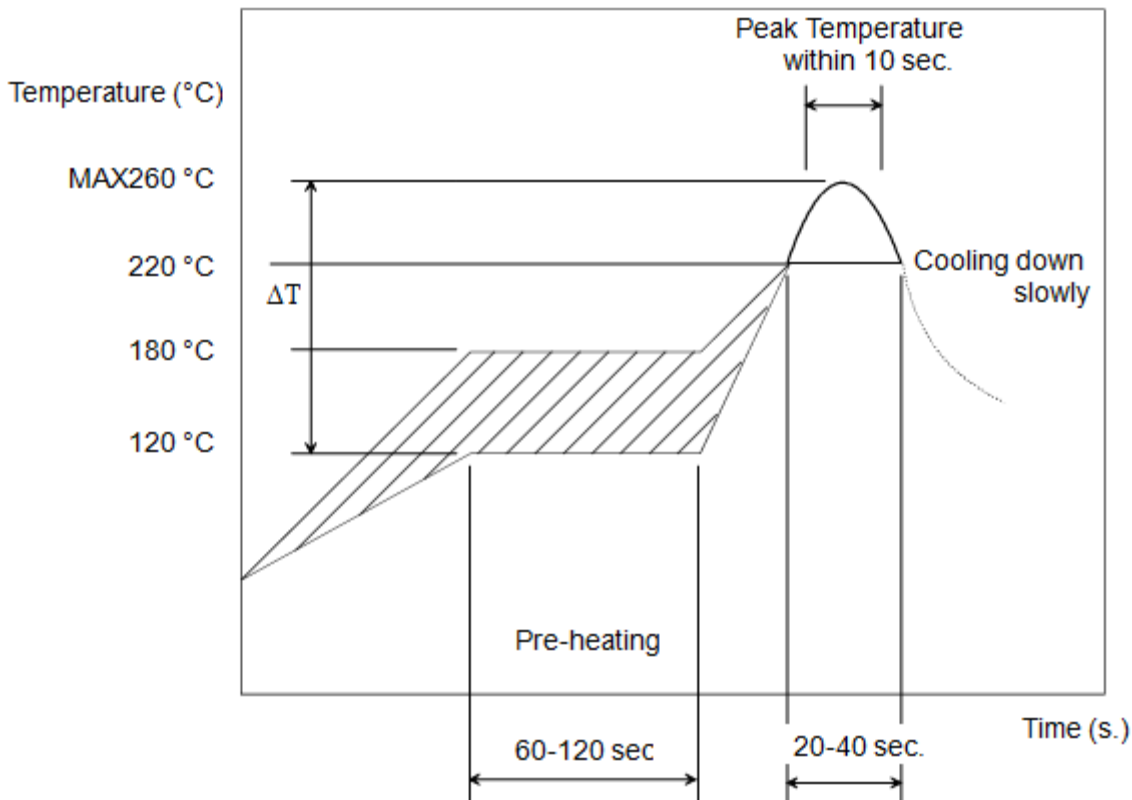

Use rosin type flux or weakly active flux with a chlorine content of 0.2 wt % or less.

5. Cleaning Conditions:

The product is not designed to be cleaned after soldering.

6. Operational Environment Conditions:

Products are designed to work for electronic products under normal environmental conditions (ambient temperature, humidity and pressure). Therefore, products have no problems to be used under the similar conditions to the above-mentioned. However, if products are used under the following circumstances, it may damage products and leakage of electricity and abnormal temperature may occur.

- In an atmosphere containing corrosive gas (Cl₂, NH₃, SO_x, NO_x etc.).
- In an atmosphere containing combustible and volatile gases.
- In a dusty environment.
- Direct sunlight
- Water splashing place.
- Humid place where water condenses.
- In a freezing environment.

If there are possibilities for products to be used under the preceding clause, consult with Murata before actual use.

If static electricity is added to this product, degradation and destruction may be produced. Please use it after consideration enough so that neither static electricity nor excess voltage is added at the time of an assembly and measurement.

If product malfunctions may result in serious damage, including that to human life, sufficient fail-safe measures must be taken, including the following:

- (1) Installation of protection circuits or other protective device to improve system safety
- (2) Installation of redundant circuits in the case of single-circuit failure

7. Input Power Capacity:

Products shall be used in the input power capacity as specified in this specifications.

Inform Murata beforehand, in case that the components are used beyond such input power capacity range.

8. Limitation of Applications:

The products are designed and produced for application in ordinary electronic equipment (AV equipment, OA equipment, telecommunication, etc). If the products are to be used in devices requiring extremely high reliability following the application listed below, you should consult with the Murata staff in advance.

- Aircraft equipment.
- Aerospace equipment
- Undersea equipment.
- Power plant control equipment.
- Medical equipment.
- Transportation equipment (vehicles, trains, ships, etc.).
- Automobile equipment which includes the genuine brand of car manufacture, car factory-installed option and dealer-installed option.
- Traffic signal equipment.
- Disaster prevention / crime prevention equipment.
- Data-processing equipment.
- Application which malfunction or operational error may endanger human life and property of assets.
- Application which related to occurrence the serious damage
- Application of similar complexity and/ or reliability requirements to the applications listed in the above.



Note:

Please make sure that your product has been evaluated and confirmed against your specifications when our product is mounted to your product.

Product specifications are subject to change or our products in it may be discontinued without advance notice.

This catalog is for reference only and not an official product specification document, therefore, please review and approve our official product specification before ordering this product.